

# APPLICATIONS

# REVISIONS

NEXT ASSY	USED ON	LTR	DESCRIPTIONS	DATE	APPROVED
	MULTIPLE	—	BASELINE RELEASE	05/25/94	

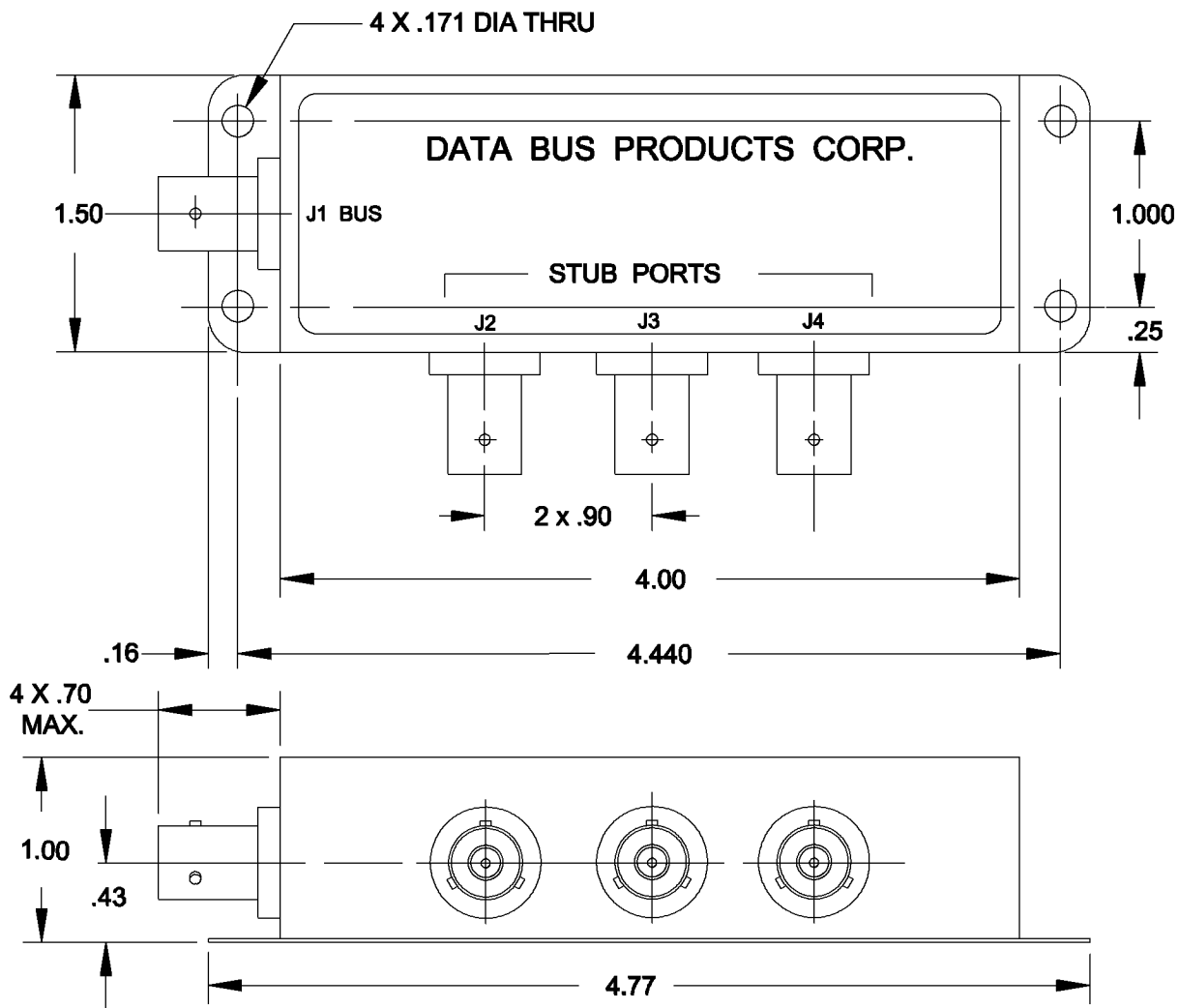

## INTERFACE CONTROL DRAWING

REV																															
LTR																															
SHT																															
NO.	1	2	3	4	5	6	7	8	9	10	11	12	13	14	15	16	17	18	19	20	21	22	23	24	25	26	27	28	29	30	
—	—																														

UNLESS OTHERWISE SPECIFIED DIMENSIONS ARE IN INCHES TOLERANCES ON FRACTIONS DECIMALS ANGLES 2PL ± .03 3PL ± .010	CONTRACT NO.		<b>DATA BUS PRODUCTS CORP.</b> MANHASSET, NEW YORK 11030 <b>COUPLER, DATA BUS, 3 STUB</b> <b>MIL - STD - 1553B, 3 LUG</b> <b>INTERNALLY TERMINATED</b>		
	PREPARED <b>W.S.</b>				
	CHECKED <b>940525</b>				
	ENGR.				
MATERIAL  SEE PARAGRAPH 2.1	ENGR.		SIZE	CODE IDENT NO.	DRAWING NO.
	ENGR.		<b>A</b>	<b>03JJ7</b>	<b>DBP30011</b>
	APPROVED		SCALE : NONE		REV. —
	APPROVED BY OTHER ACTIVITY		SHEET 1 OF 2		

# REVISIONS

LTR	DESCRIPTIONS	DATE	APPROVED
—	BASELINE RELEASE	05 / 25 / 94	

- 1.0 ELECTRICAL SPECIFICATIONS: IAW MIL - STD - 1553B.
- 1.1 COMMON MODE REJECTION: -55.0dB MAX @ 1.0MHz.
- 1.2 DROOP: 20% MAX (250kHz).
- 1.3 OVERSHOOT & RINGING:  $\pm 1.0V$  PEAK (250kHz) SQUARE WAVE WITH 100ns MAX RISE & FALL TIME).
- 1.4 STUB VOLTAGE: 1.0V TO 14.0V P-P; LINE TO LINE; SIGNAL VOLTAGE, TRANSFORMER COUPLING.
- 1.5 INPUT IMPEDANCE OF BUS: 1000 OHMS MIN. (75kHz - 1.0MHz), STUB WITH OPEN CIRCUIT.
- 1.6 FAULT PROTECTION: 58.5 OHMS  $\pm 2\%$  RESISTOR IN SERIES WITH TRANSFORMER WINDING ON BUS SIDE.
- 1.7 RESISTOR VALUE: 1 WATT IAW MIL - R - 39017, R1 - R6 (75%  $Z_0$ ).  
 NOMINAL LINE IMPEDANCE OF BUS ( $Z_0$ ): 78 OHMS.  
 R7 = 78 OHMS 2 WATT IAW MIL - R - 39007
- 2.0 MECHANICAL SPECIFICATIONS:
- 2.1 MATERIAL: ENCLOSURE: COLD ROLLED STEEL, .031 THK..
- 2.1.1 MOUNTING PLATE: COLD ROLLED STEEL, .042 THK..
- 2.2 FINISH: BLACK ENAMEL PER TT - E - 529, COLOR IAW FED - STD - 595, #27028, OVER HOT TIN DIP.
- 2.3 CONNECTORS: BJ77 3 LUG (TROMPETER OR EQUIV.) J1 THRU J4.  
 MATING CONNECTOR FOR REFERENCE: PL75 (TROMPETER OR EQUIV.).
- 3.0 ENVIRONMENTAL:
- 3.1 OPERATING TEMPERATURE RANGE: -55°C TO 125°C.

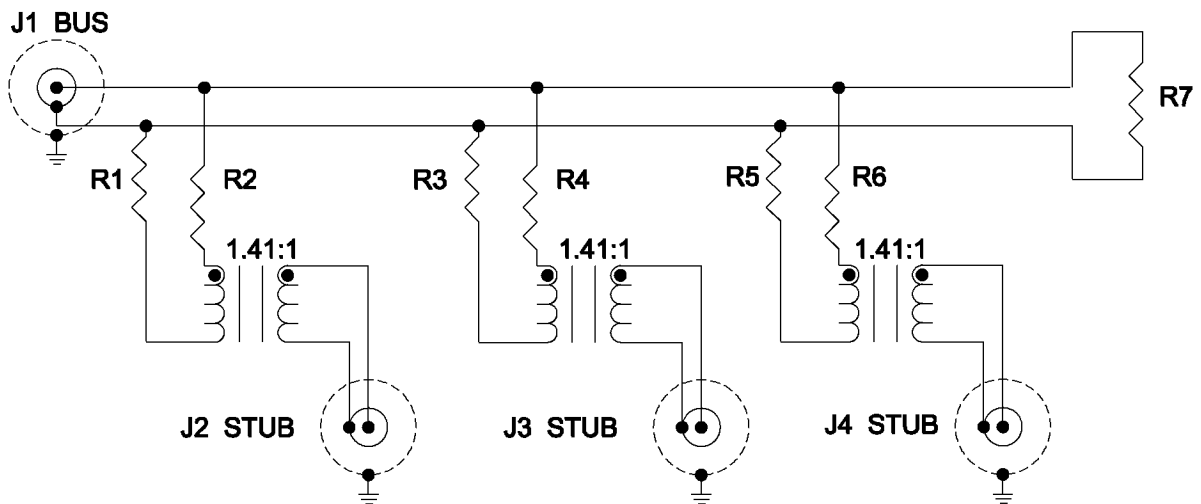

## SCHMATIC DIAGRAM

$\perp$  = ENCLOSURE GROUND

SIZE <b>A</b>	CODE IDENT NO. <b>03JJ7</b>	DRAWING NO. <b>DBP30011</b>
SCALE: NONE	REV. —	SHEET 2 OF 2