

REVISIONS

| LTR | DESCRIPTIONS | DATE | APPROVED |
|-----|------------------|--------------|----------|
| — | BASELINE RELEASE | 04 / 21 / 99 | |

- 1.0 ELECTRICAL SPECIFICATIONS: IAW MIL - STD - 1553B.
- 1.1 COMMON MODE REJECTION: -55.0dB MAX @ 1.0MHz.
- 1.2 DROOP: 20% MAX (250kHz).
- 1.3 OVERSHOOT & RINGING: ± 1.0V PEAK (250kHz) SQUARE WAVE WITH 100ns MAX RISE & FALL TIME).
- 1.4 STUB VOLTAGE: 1.0V TO 14.0V P-P; LINE TO LINE; SIGNAL VOLTAGE, TRANSFORMER COUPLING.
- 1.5 INPUT IMPEDANCE OF BUS: 600 OHMS MIN. (75kHz - 1.0MHz), STUB WITH OPEN CIRCUIT.
- 1.6 FAULT PROTECTION: 58.5 OHMS ± 2% RESISTOR IN SERIES WITH TRANSFORMER WINDING ON BUS SIDE.
- 1.7 RESISTOR VALUE: 1 WATT IAW MIL - R - 39017, R1 - R10 (75% Z_0).
NOMINAL LINE IMPEDANCE OF BUS (Z_0): 78 OHMS.

2.0 MECHANICAL SPECIFICATIONS:

- 2.1 MATERIAL: ENCLOSURE: COLD ROLLED STEEL, .031 THK..
- 2.1.1 MOUNTING PLATE: COLD ROLLED STEEL, .042 THK..
- 2.2 FINISH: BLACK ENAMEL PER TT - E - 529, COLOR IAW FED - STD - 595, #27028, OVER HOT TIN DIP.
- 2.3 CONNECTORS: BJ3157/BJ3150 THREADED (TROMPETER OR EQUIV.) J1 THRU J7.
MATING CONNECTOR FOR REFERENCE: PL3155 (TROMPETER OR EQUIV.).

3.0 ENVIRONMENTAL:

- 3.1 OPERATING TEMPERATURE RANGE: -55°C TO 125°C.

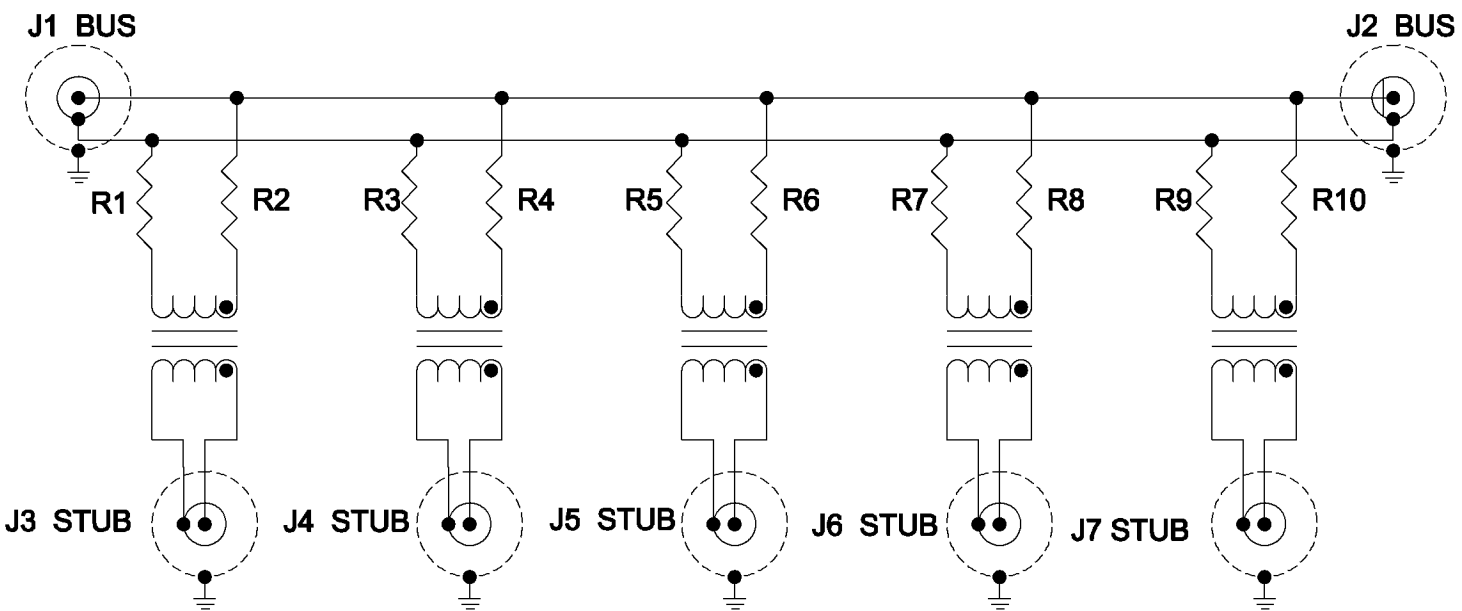

SCHEMATIC DIAGRAM

⊥ = ENCLOSURE GROUND

| | | |
|--------------|----------------|-------------------|
| SIZE | CODE IDENT NO. | DRAWING NO. |
| A | 03JJ7 | DBP50040XS |
| SCALE : NONE | REV. — | SHEET 2 OF 2 |