

APPLICATIONS

REVISIONS

NEXT ASSY	USED ON	LTR	DESCRIPTIONS	DATE	APPROVED
	MULTIPLE	—	BASELINE RELEASE	08 / 02 / 94	WS

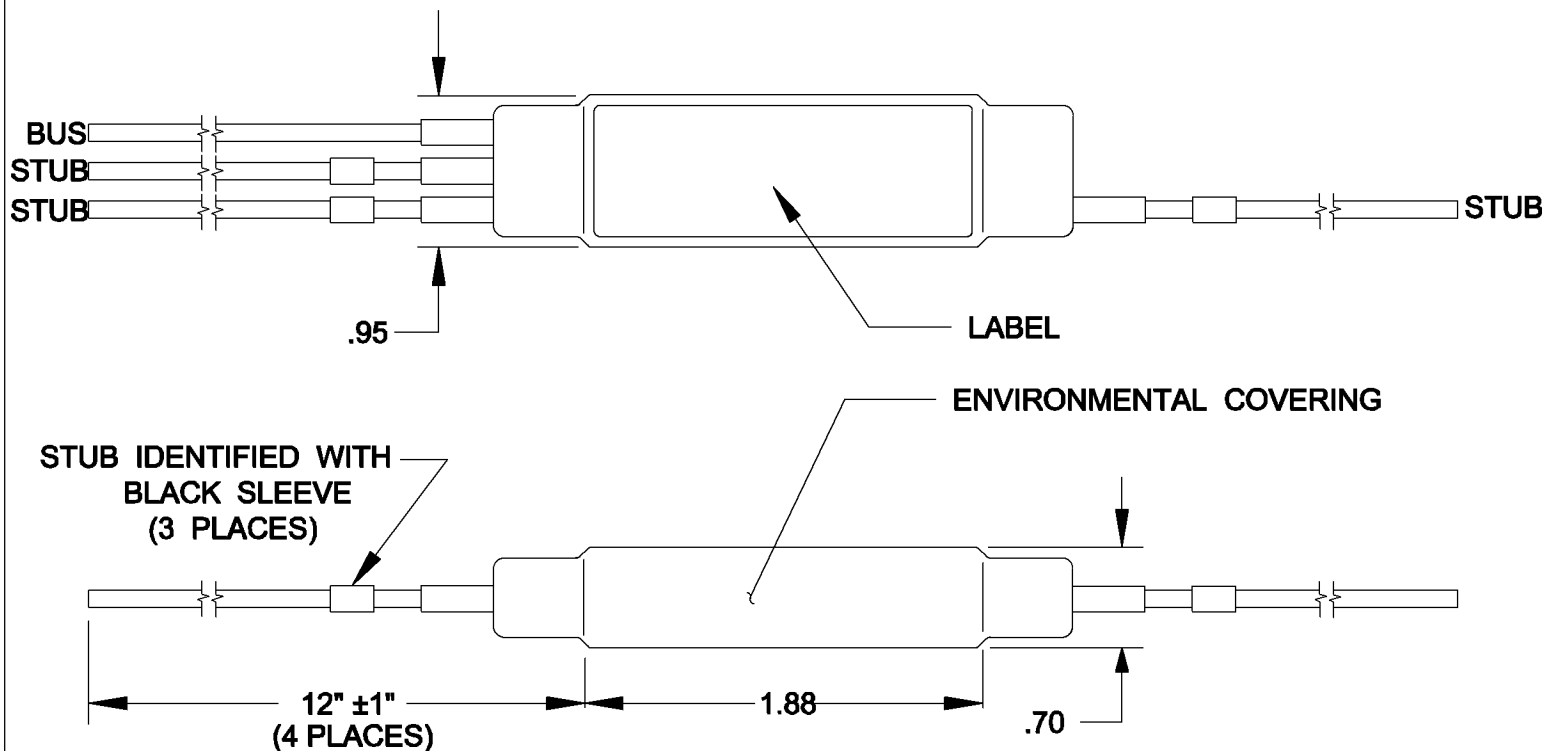

INTERFACE CONTROL DRAWING

REV	LTR	1	2	3	4	5	6	7	8	9	10	11	12	13	14	15	16	17	18	19	20	21	22	23	24	25	26	27	28	29	30
UNLESS OTHERWISE SPECIFIED DIMENSIONS ARE IN INCHES TOLERANCES ON FRACTIONS DECIMALS ANGLES 2PL ± .03 3PL ± .010		CONTRACT NO.												DATA BUS PRODUCTS CORP. MANHASSET, NEW YORK 11030 COUPLER, INLINE, INTERNALLY TERMINATED, TRIPLE STUB MIL - STD - 1553B																	
MATERIAL		PREPARED																													
SEE PARAGRAPH 2.1		ENGR.												DRAWING NO.																	
		APPROVED												SIZE				CODE IDENT NO.				DRAWING NO.									
		APPROVED BY OTHER ACTIVITY												A				03JJ7				DBP32005									
SCALE : NONE																		REV. —				SHEET 1 OF 2									

REVISIONS

LTR	DESCRIPTIONS	DATE	APPROVED
—	BASELINE RELEASE	08 / 02 / 94	WS

- 1.0 ELECTRICAL SPECIFICATIONS: IAW MIL - STD - 1553B.
- 1.1 COMMON MODE REJECTION: -55.0dB MAX @ 1.0MHz.
- 1.2 DROOP: 20% MAX (250kHz).
- 1.3 OVERSHOOT & RINGING: ± 1.0V PEAK (250kHz) SQUARE WAVE WITH 100ns MAX RISE & FALL TIME).
- 1.4 STUB VOLTAGE: 1.0V TO 14.0V P - P; LINE TO LINE; SIGNAL VOLTAGE, TRANSFORMER COUPLING.
- 1.5 INPUT IMPEDANCE OF BUS: 1000 OHMS MIN. (75kHz - 1.0MHz), STUB WITH OPEN CIRCUIT.
- 1.6 FAULT PROTECTION: 58.5 OHMS ± 2% RESISTOR IN SERIES WITH TRANSFORMER WINDING ON BUS SIDE.
- 1.7 RESISTOR VALUE: 1 WATT IAW MIL - R - 39007, R1 - R6 (75% Zo). NOMINAL LINE IMPEDANCE OF BUS (Zo): 78 OHMS. R7 = 78 OHMS.
- 2.0 MECHANICAL SPECIFICATIONS:
- 2.1 MATERIAL: ENCLOSURE: COLD ROLLED STEEL, .031 THK. MAX..
- 2.2 FINISH: ENVIRONMENTAL PROTECTIVE COVERING: FLAME RETARDED, RADIATION CROSSLINKED POLYOLEFIN.
- 2.3 CABLE: PER MIL - C - 17/176-00002.
- 3.0 ENVIRONMENTAL:
- 3.1 OPERATING TEMPERATURE RANGE: -55°C TO 125°C.

SCHEMATIC DIAGRAM

CASE GROUND

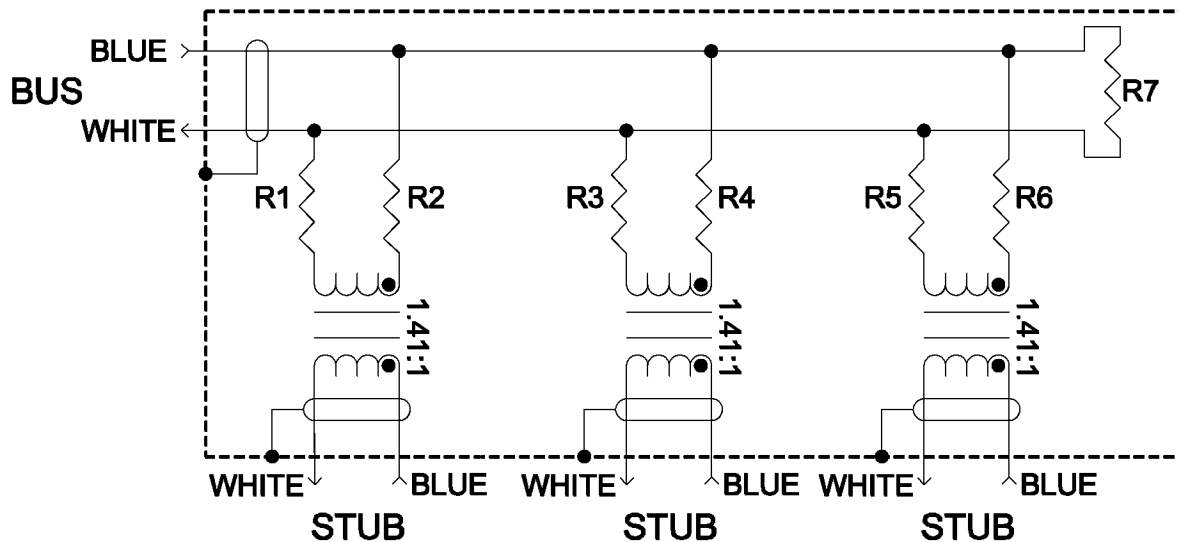

SIZE	CODE IDENT NO.	DRAWING NO.
A	03JJ7	DBP32005
SCALE : NONE	REV. —	SHEET 2 OF 2